

R-11 and R-30

R-Series Electric Actuators with Integral Driver

Applications

Woodward's R-11 and R-30 electric actuators provide high torque rotary travel to precisely position various types of control valves and other mechanisms that operate in high-temperature, high-vibration locations. In reciprocating engine applications, these valves may include: fuel throttles, wastegates, exhaust gas recirculation (EGR), compressor recirculation (bypass), waste heat recovery (WHR), and exhaust. Additional applications on reciprocating engines include variable turbine geometry (VTG) turbocharger actuation.



Description

The R-11 and R-30 actuators accept a position command and use a brushless DC electric motor driving an integral gear box to move the output shaft through 73 degrees of rotational output position. The cast metal modular design includes an electronic control module and integral motor housing that attach directly to the gearbox assembly. The 73 degrees of travel enables the actuator to be connected directly to butterfly-type throttles, eliminating the need for failure-prone intermediate linkage. This larger rotary travel also provides more useful work output than actuators with the same torque output but with less rotary travel. (For more information on work vs torque, see Woodward application note 51214.)

Both the R-11 and R-30 actuators accept a position command signal from some other controlling device to position the actuator's output shaft. The actuators output shaft is moved to match the requested position. Internal electronic feedback assures the output shaft moves precisely to the requested position. These actuators accept either a 4 to 20 mA, 0 to 200 mA, or PWM (pulse width modulated) command signal while providing a 4 to 20 mA output shaft position signal that external devices can use as direct feedback of the output shaft's position. Three discrete inputs select the type of command input signal to be used and the direction of the output shaft on an increase of command signal. A single discrete output can indicate when a shutdown is active. A key-switch input safely powers down the internal control module and motor while keeping the unit connected to the system's power source. An access plate allows electrical connections to be made directly on the control module in the actuator housing and all wiring goes through gland nuts to maintain an ingress protection rating of IP67. The actuators are able to operate over a temperature range of $-40\text{ }^{\circ}\text{C}$ to $+105\text{ }^{\circ}\text{C}$. Some position accuracy is compromised from $-40\text{ }^{\circ}\text{C}$ to $-30\text{ }^{\circ}\text{C}$.

This product specification describes part numbers 8410-001 (R-11) and 8410-002 (R-30).

- High resolution
- High torque, low current electric actuator
- $-40\text{ }^{\circ}\text{C}$ to $+105\text{ }^{\circ}\text{C}$ operating range
- Lower weight than LAT type actuators
- Accurate, non-contacting, position sensing
- Custom cabling options

Installation

Both the R-11 and R-30 have the same physical dimensions, only the internal gearing is different. They can be mounted in any orientation and are completely self-contained.

All input and output signals run through two M20 threaded ports, using cable glands as needed to maintain the Class I, Division 2 / Zone 2 and Type 4 Enclosure Watertight. Field wiring is connected to internal screwless cage-clamp-style terminal blocks.

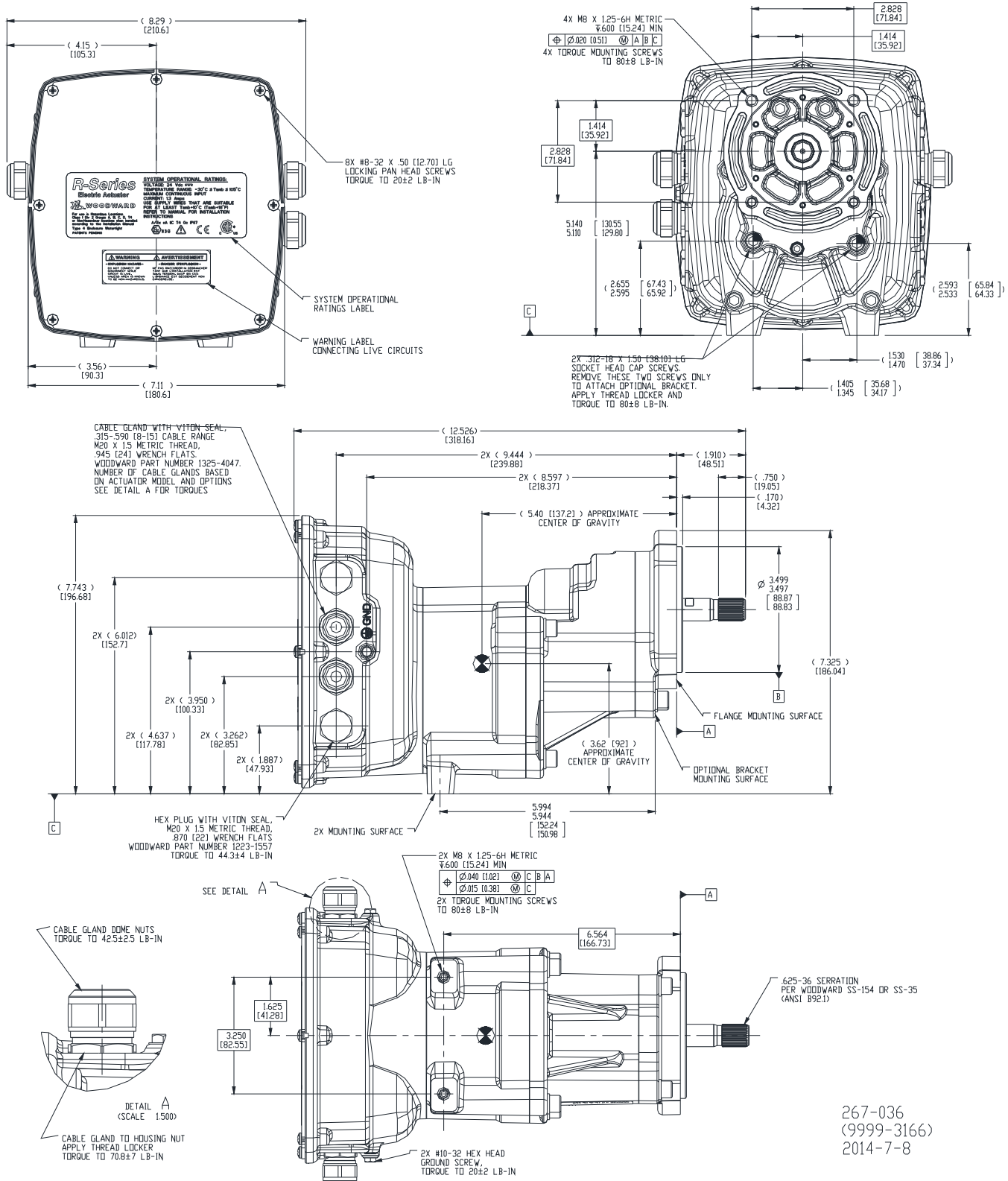

R-11 and R-30 Outline Drawings
(Do not use for construction)

267-036
(9999-3166)
2014-7-8

Specifications

General

Model	Work Output Continuous *	Torque Output Transient	Torque Output Continuous	Maximum Input Power Transient **	Maximum Input Power Continuous **	Maximum Current Transient **	Maximum Current Continuous **	Weight
R-11	7.2 J 5.3 ft-lb	11 N·m 8.1 lb-ft	5.5 N·m 4 lb-ft	89 W	24 W	3.7 A	1.0 A	8.0 kg 17.6 lb
R-30	19.6 J 14.5 ft-lb	30 N·m 22.1 lb-ft	15 N·m 11 lb-ft	89 W	24 W	3.7 A	1.0 A	8.3 kg 18.2 lb

* Continuous Work Output is measured over 73° of rotation. Good control of fuel racks requires the actuator to deliver a defined force over a defined distance, also known as *work*. Since *work* is the ultimate requirement, rotary actuators are best sized and compared based on continuous work rating: Continuous work (joules) = 0.01745 x continuous torque (N·m) x rotation angle (degrees)

** at 24 Vdc nominal

Inputs and Outputs

Power Input	18–32 Vdc with out-of-range diagnostics
Command Input	PWM: 8–32 Vdc, 100 to 2000 Hz (accepts push-pull and high-side or low-side open collector) Analog: 0–200 mA, 4–20 mA,
Output Shaft Rotation	73 degrees ±2 degrees
Position Feedback Output	4–20 mA corresponding to 0 % to 100 % travel
Discrete Input	Key-switch low power standby mode. Applying input power to the key-switch input activates the actuator, making it ready to position in less than 300 ms. Removing the key-switch input power safely shuts down the actuator and its power draw is less than 2 mA.
Discrete Output	Normally “ON” and turns “OFF” to indicate shutdown is active

Performance

Parameter	Specification
Accuracy	±1.36 % over the full rotational travel, from –30 to +105 °C, + input signal error. At < –30 °C, the position error can grow to ~ ±5%.
Max Slew Time (10 % to 90 % travel)	R-11 = 75 ms R-30 = 105 ms
Small Signal Bandwidth	6 Hz (minimum)
Repeatability	≤1.0 % of full stroke at 25 °C
Gearbox Backlash	< 0.5 degrees
Side Load on Output Shaft	396 N / 89 lb (maximum)
Thrust Load on Output Shaft	67 N / 15 lb (maximum)
Maximum Load Inertia	R-11 < 2.19E-3 kg·m ² (1.94E-2 in-lb-s ²) R-30 < 5.26E-3 kg·m ² (4.66E-2 in-lb-s ²)

Environmental

Specification Item	Tested to the Following Specifications
Operating Temperature Limits	–40 °C to +105 °C (from –30 °C to –40 °C, position error can grow to ±5% of full travel) Under all conditions, the Temperature Monitoring Zone must remain below 105 °C. See Mechanical Installation section of the manual for discussion of this specification item.
Storage Temperature	–40 °C to +125 °C, unpowered
Mechanical Shock	US MIL-STD-810F, Method 516.5, Procedure 1, 40 G peak, 11 ms duration, saw-tooth pulse
Ingress Protection	IP67 per IEC 60529, NEMA Type 4 enclosure
Humidity	95 % Relative Humidity—12 hours at 60 °C and 7 hours at 25 °C with 5 hours of transition for 5 complete cycles
Chemical Resistance	The actuator uses materials proven capable of withstanding normal engine environment chemicals per SAE J1455, such as diesel fuel, engine oil, and antifreeze.

Mechanical Vibration

Power Spectral Density (PSD) must not exceed the level or frequency as shown in the curve below while the actuator is running, as measured at the actuators mounting surface.

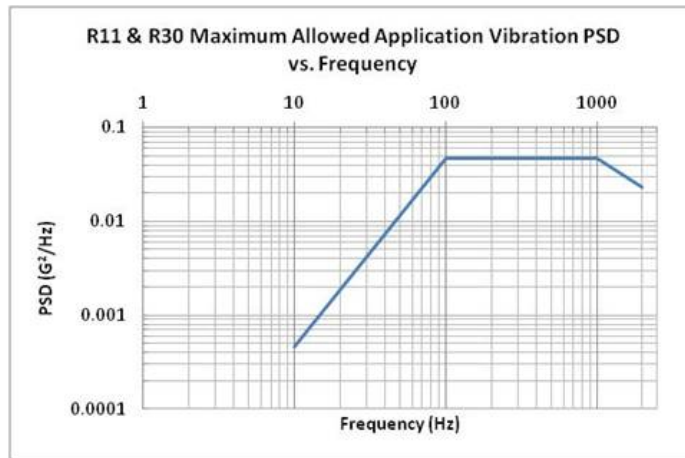

Frequency (Hz)	Allowed PSD Level (G ² /Hz)
10	0.000466101
100	0.046610131
1000	0.046610131
2000	0.023305065

Regulatory Compliance

European Compliance for CE Mark:

- **EMC Directive:** 2004/108/EC
- **ATEX Directive:** 94/9/EC Zone 2, Category 3, Group II G, Ex nA IIC T4 Gc IP67

Other European Compliance:

- **Machinery Directive:** Compliant as a partly completed machinery per 2006/42/EC

North American Compliance:

- **CSA Certified** for Class I, Division 2, Groups A, B, C, D, T4 at 105 °C Ambient
For use in Canada and the United States
- **CSA Certified** for Class I, Zone 2, Category 3, Group II G, AEx nA IIC T4 Gc IP67
For use in Canada and the United States
- **CSA Certified** for Ordinary Locations

Refer to manual 26729 for more detailed information.



PO Box 1519, Fort Collins CO 80522-1519, USA
1000 East Drake Road, Fort Collins CO 80525, USA
Phone +1 (970) 482-5811 • Fax +1 (970) 498-3058
Email and Website—www.woodward.com

Woodward has company-owned plants, subsidiaries, and branches, as well as authorized distributors and other authorized service and sales facilities throughout the world. Complete address / phone / fax / email information for all locations is available on our website.

This document is distributed for informational purposes only. It is not to be construed as creating or becoming part of any Woodward contractual or warranty obligation unless expressly stated in a written sales contract.

Copyright © Woodward 2013–2015, All Rights Reserved

For more information contact: