

SA-35

STEAM ATOMIZING DESUPERHEATER



Copes-Vulcan has been providing control valves and desuperheaters for the power, process and nuclear industries since 1903. SPX provides a wide range of valves for the control of pressure, temperature and flow-induced noise in all types of power plants. Products include severe service and general service control valves, variable orifice desuperheaters, Raven™, trim and steam conditioning valves and nuclear control valves, as well as custom designed specialty valves. Copes-Vulcan is recognized worldwide as a leader in valves for severe and critical service applications. Our strength lies in our ability to provide innovative valve solutions for our customers' application needs.

Finding innovative ways to help the world meet its ever growing demand for energy is a key focus for SPX. SPX provides creative solutions that serve global industrial markets in a myriad of ways. Our ideas are helping build more efficient power plants and renovate older existing facilities. SPX supplies a wide range of components – from air preheaters to filter systems for various power and energy applications.

With operations in over 35 countries, SPX has the global experience and regional presence, products and powerful ideas it takes to help our customers compete more effectively, and more efficiently deliver power to almost any part of the world.

SA-35 Steam Atomizing Desuperheater

The Copes-Vulcan SA-35 was developed to obtain a more uniform spray pattern under varying load conditions where no pressure drop in the steam header can be tolerated. Steam atomizing allows for higher turndown (up to 25:1) with varying load conditions.

OPERATIONAL FEATURES

Cooling liquid is introduced into the steam header through a stainless steel nozzle assembly, which uniquely divides one large jet of liquid into many small jets. Just prior to entrance into the main header, each jet is bombarded by a higher pressure steam jet, creating a fine mist which enters the stream flow without the need of a thermal liner inside the main header.

The SA-35 Desuperheater thus reduces the size of the liquid particles so that the droplets can be quickly and efficiently evaporated. Downstream temperatures can be controlled to within 15°F (9°C) of saturation.

The stainless steel nozzle is machined from one piece and shoulders into the nozzle head so that it becomes completely trapped after assembly of the nozzle clamp which is screwed and seal welded to the nozzle head. Hard faced overlay in the nozzle head minimizes erosion wear. The thermal sleeve around the liquid tube insures uniform expansion with the steam tube, thereby minimizing thermal stresses due to unequal elongation of the liquid and atomizing steam tubes.

Due to its narrow silhouette, the SA-35 Desuperheater causes no appreciable restriction in the header. This desuperheater is made in four sizes, in pressure classes up to and including class 1500.

The cooling liquid is introduced through a series of small orifices which are drilled circumferentially into the nozzle. Small rectangular slots are milled ninety (90) degrees to the drilled holes. Atomizing steam passes through each of the slots and blasts each of the cooling liquid jets. Liquid pressure of only 10-40 psi (70–280 kPa) above header pressure is all that is necessary to introduce the cooling medium.

Atomizing steam flow is constant as the flow in the header decreases from maximum rate, until only atomizing steam is flowing. This results in improved atomization at low flows to offset the decreasing benefit obtained from the mixing and transporting capacity of the steam in the header at a reduced rate of flow.

This characteristic is unique, and is the reverse of most other types of desuperheaters.

DIMENSIONS

DESUPERHEATER SIZE	HEADER SIZE
3-4	4-16" (100-400mm)
4-6	6-18" (150-450mm)
6-8	8-20" (200-500mm)
8-10	10-24" (250-600mm)

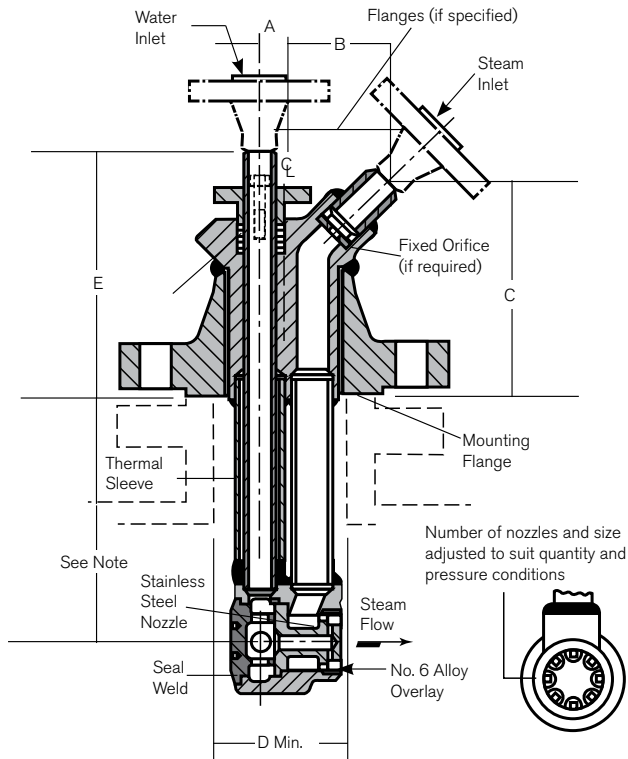

Typical product applications

Refineries



Chemical



Pulp & Paper



SIZE	DIMENSIONS (INCHES) - ALL HEADER SIZES																
	MOUNTING FLANGE	WATER CONN.	STEAM CONN.	A	B	C				D MIN.	TO 600 STD.			900 & 1500 STD.			
						150	300	400	600		E	H	CONN. PIPES SCHEDULE	C	E	H	CONN. PIPES SCHEDULE
3-4	3	.5	.5	.5	3.875	6.25	6.625	—	7	3	7	6	80	7	8	7	—
4-6	4	.75	1	.8125	4.25	6.75	7	7.5	8	4	9	6	80	8	10	7	160
6-8	6	1.25	1.5	1.125	5	7.875	8.25	8.75	9.25	6	10	6.5	80	10	11	8.5	160
8-10	8	2	2	1.375	6	8.5	8.875	9.375	10	8	11	7	80	11	13	9	160

NOTE: Any size desuperheater may be mounted on any header size larger than minimum size listed below. Extension pipe lengths are varied to locate sprayhead at center of header up to maximum size listed. No increase is made for larger headers causing head to be slightly off center.

PRINCIPLE OF OPERATION

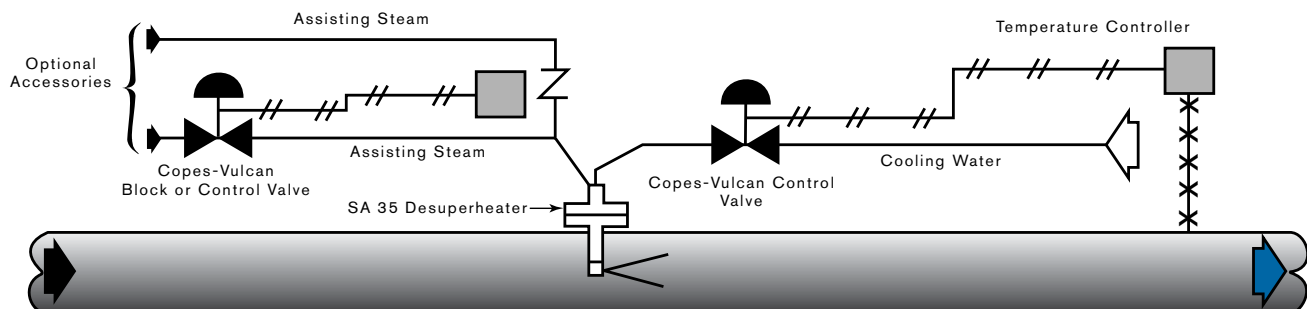

Temperature impulse signal from controller actuates cooling water valve flow to desuperheater. Atomizing steam may require a pressure reducing valve and pressure controller or check valve only, depending upon atomizing steam source conditions.



Global locations

SPX FLOW TECHNOLOGY

5620 West Road
McKean, PA 16426
United States of America
+1 814 476 5800

SPX FLOW TECHNOLOGY

Road Two, Industrial Estate
Winsford, Cheshire CW7 3QL
England
+44 1606 552041

SPX FLOW TECHNOLOGY

25 International Business Park
#03-03/12 German Centre
Singapore 609916
+65 6264 4366

SPX FLOW TECHNOLOGY

6F Treasury Building
1568 Hua Shan Road
Shanghai 200052
PR China
+86 21 2208 5888

Based in Charlotte, North Carolina, SPX Corporation (NYSE: SPW) is a global Fortune 500 multi-industry manufacturing leader. For more information, please visit www.spx.com

SPX FLOW TECHNOLOGY

5620 West Rd.
McKean, PA 16426
P: (814)476-5800
F: (814)476-5854
E: cv@spx.com

SPX reserves the right to incorporate our latest design and material changes without notice or obligation.

Design features, materials of construction and dimensional data, as described in this bulletin, are provided for your information only and should not be relied upon unless confirmed in writing. Please contact your local sales representative for product availability in your region. For more information visit www.spx.com.

The green ">" is a trademark of SPX Corporation, Inc.

ISSUED 03/2012 CV-1164-US

COPYRIGHT © 2012 SPX Corporation